

The ACCO-USB converter enables the RS-485 communication bus to be connected to PC computer through a USB serial port. It is dedicated to interfacing with the ACCO access control system. A computer with installed ACCO-SOFT-LT program enables central management and programming of the ACCO system. The ACCO system structure is based on the single ACCO-KP and ACCO-KP-PS modules of the door controller. Communication in the system is provided according to the RS-485 standard. The computer is not required for normal operation of the system. The modules operate as fully autonomous devices, all data necessary for work being stored in their memory. Several ACCO-USB converters can be connected to the computer. Thus, using one computer makes it possible to simultaneously manage several ACCO systems.

Another advantage of the ACCO-USB converter is the option to directly connect the ACCO-USB-CZ proximity card reader. This makes adding new users an easier job for the system administrator.

1. Converter description

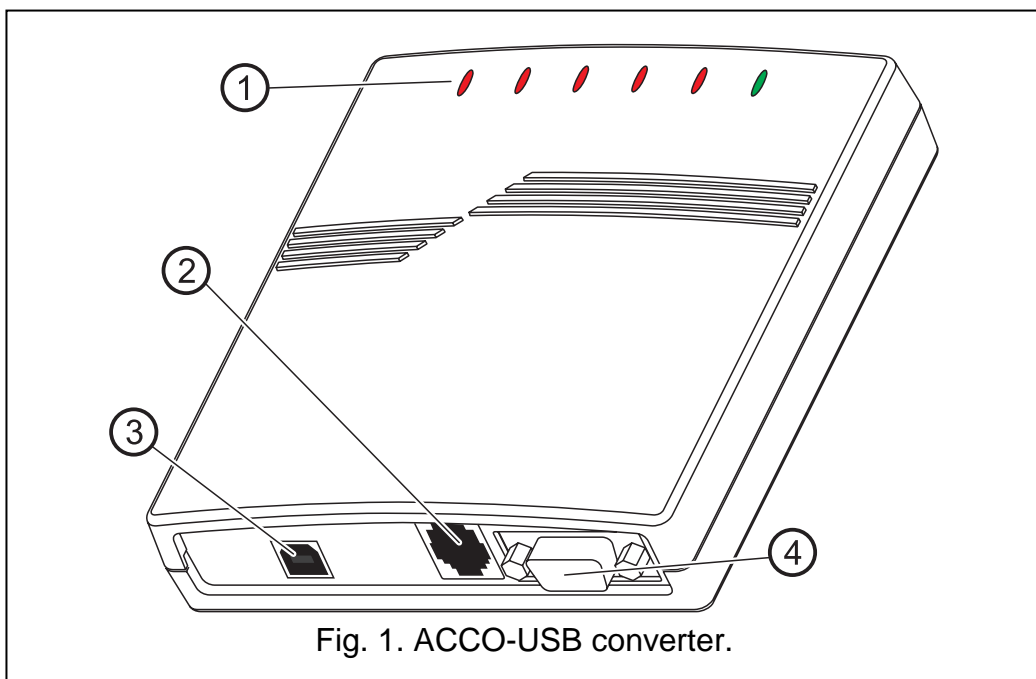

Fig. 1. ACCO-USB converter.

Explanations for Fig. 1:

1 – LED indicators:

- PWR** - lit when the converter is connected by means of USB cable to the computer and the computer is turned on
- HEAD** - lit when the ACCO-USB-CZ proximity card reader is connected to the converter
- READ** - lit when the reader is waiting for proximity card to be read in
- ERR** - blinking when communication between converter and at least 1 module is lost
- TX** - blinking when data are being sent to the computer
- RX** - blinking when data are being received from the computer

2 – RJ-45 socket for connecting the ACCO-USB-CZ proximity card reader.

- 3 – **USB socket** for connecting the converter to computer.
- 4 – **DB-9 socket** for connecting the RS-485 communication bus.

2. Connecting the converter to computer

The ACCO-USB converter can be connected to a PC computer with the Windows 98/ME/2000/XP/VISTA system installed. The connection is to be made by means of the USB cable delivered with the converter. When the connection is ready, the green LED designated PWR will light up in the converter. The Windows system will automatically detect connection of a new device and launch the wizard to guide the user through the procedure of installing drivers for the new hardware. The drivers for the ACCO-USB converter are provided on a CD delivered with the device. Some versions of the Windows operating system may warn that the software has not passed conformity tests. Installation of the drivers should be continued despite these warnings. When the drivers are installed, an extra COM port will be available in the computer. Using this port and the ACCO-USB converter, the ACCO-SOFT-LT program will communicate with modules connected to the RS-485 bus. Two new devices will appear in the manager window (USB <--> RS 485 Serial Converter and Acco-USB Serial Port).

After the converter is connected to the computer and drivers installed, the device will operate service-free.

3. RS-485 communication bus

The ACCO-KP and ACCO-KP-PS door controller modules and the ACCO-USB converter should be connected according to the bus topology (using the "star" type topology is not recommended). The RS-485 bus structure is shown in Fig. 2.

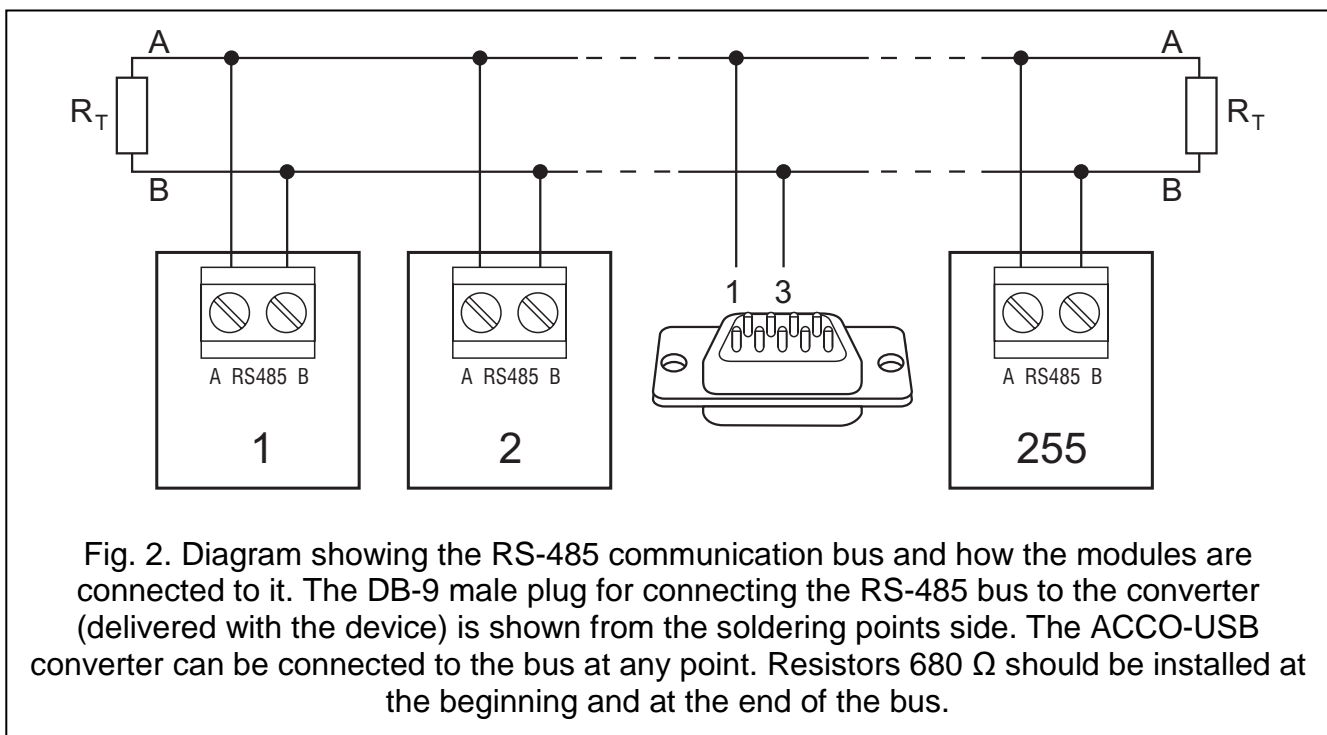

To build the RS-485 communication bus, use the UTP (unscreened twisted pair) type of cable. Only one pair of conductors is used. The maximum length of the bus is 1200 m and up to 255 modules can be connected to it. When connecting modules to the bus, bear in mind that an individual address must be set on them. The address must not be repeated! None of the modules may have address 0 set on them. The RS-485 bus should be loaded at the beginning and at the end with resistors 680 Ω . This is particularly important when the bus is long and the transmission rates are high.

Note: In case of any problems with communication through the RS-485 bus, connecting the common ground of all modules and converter (pin 5) with an additional wire may prove helpful.

4. ACCO-USB-CZ proximity card reader

The ACCO-USB-CZ proximity card reader is the CZ-EMM reader adapted to work in conjunction with the ACCO-USB converter. The reader lead-out is terminated with the RJ-45 plug to enable connection to the converter socket. Connection of the reader is signaled by the converter LED indicator, designated HEAD.

The reader connected to the converter makes the system administrator's work easier, as it enables cards to be added to the users (wherever the word "card" is used in the manual, it means the passive transponder, which may have the form of a card, key fob etc.) without leaving the computer. In addition, the reader can be used to search for the users of unspecified cards.

The two-color LED in the reader can signal as follows:

steady red light – normal operation of the reader;

blinking green light – waiting for the card to be placed in proximity.

The buzzer in the reader can signal as follows:

1 short beep – readout of a new card code (card added) or readout of a known card code (searching for the user by the card).

2 long beeps – unknown card (searching for the user by the card).

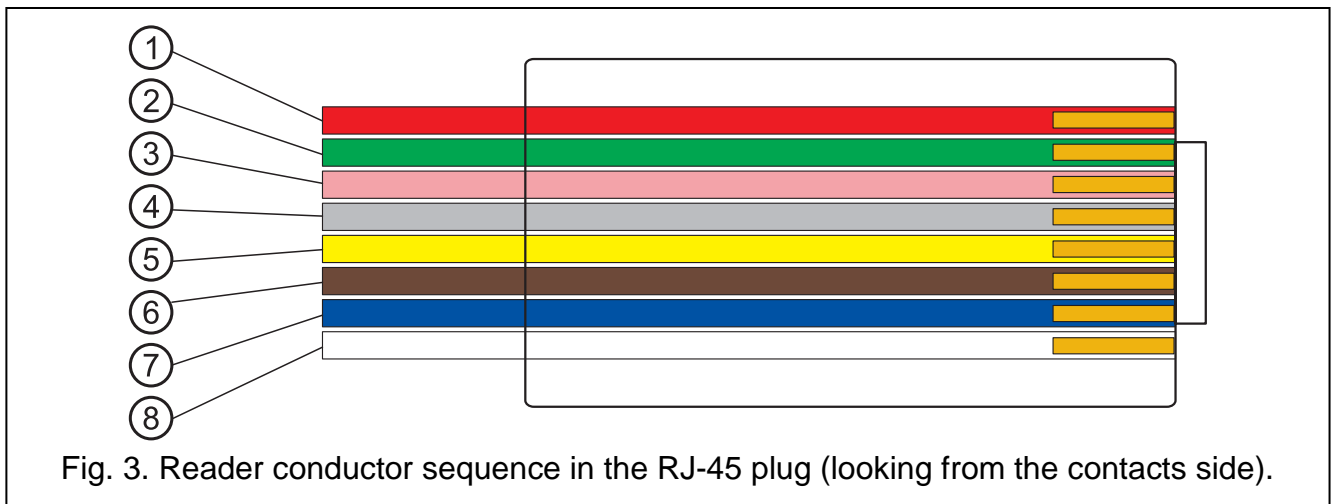

Explanations for Fig. 3:

- 1 - red wire – head supply
- 2 - green wire – data
- 3 - pink wire – LED green color control
- 4 - gray wire – LED red color control
- 5 - yellow wire – buzzer control
- 6 - brown wire – head operation blocking
- 7 - blue wire – common ground
- 8 - white wire – presence control

5. Technical data

5.1 ACCO-USB converter

Supply voltage	5 V (derived from USB port)
RS-485 bus maximum range for UTP type cable	1200 m
Maximum number of modules connected to RS-485 bus	255
Two-way transmission scheme	HALF-DUPLEX
USB standard	USB 2.0
Working temperature range	+5 °C ... +40 °C
Housing dimensions.....	125 x 114.5 x 31 mm
Weight.....	250 g

5.2 ACCO-USB-CZ proximity card reader

Supply voltage	12 V DC (derived from converter)
Maximum current consumption	50 mA
Head working frequency	125 kHz
Data transmission standard	EM-MARIN
Working temperature range	-20 °C ... +55 °C
Housing dimensions.....	120 x 80 x 29 mm
Weight.....	186 g

Latest EC declaration of conformity and product approval certificates are available for downloading on website www.satel.pl



SATEL sp. z o.o.
 ul. Schuberta 79
 80-172 Gdańsk
 POLAND
 tel. + 48 58 320 94 00
 info@satel.pl
 www.satel.pl