

1. GENERAL

The SP-500 visual-audible siren is designed for application in the burglary and assault signaling systems. The signaling function is performed in two ways: visually (by blinking of a red lamp) and acoustically (by a modulated high-volume sound signal). The 5W/12V incandescent lamp is a light source, while the sound signal is generated by means of a piezoelectric transducer. The design of the siren housing ensures a high degree of tamper protection (against opening and tearing off from the base). The electronics board is made in SMD technology and protected by impregnation against unfavorable effects of weather conditions, thus ensuring high reliability of the equipment. As the SP-500 housing is made of the highly impact resistant PC LEXAN polycarbonate, hence it features a high mechanical strength and guarantees aesthetic appearance of the siren even after many years of operation.

2. INSTALLATION

The SP-500 siren is to be installed on a flat surface, in a possibly inaccessible place, so as to minimize the risk of tampering. The siren should be screwed to its base by means of screws and expansion bolts (the screws and expansion bolts are delivered with the siren).

Note: *Make sure to leave a distance of about 0.5cm between the upper edge of the siren base and the ceiling or another element which limits the mounting position from above. The lack of such clearance can make the mounting of housing difficult.*

The tamper circuit of the siren protects it against removal of its housing or tearing it off from the wall. Both these actions will trigger an alarm. In order for the tamper circuit to function properly, the „S” **element is to be screwed down to the base**. This element has narrowings, which breaks at an attempt to tear the siren off from the wall. Be particularly careful, so as not to break these narrowings when screwing the device to the base.

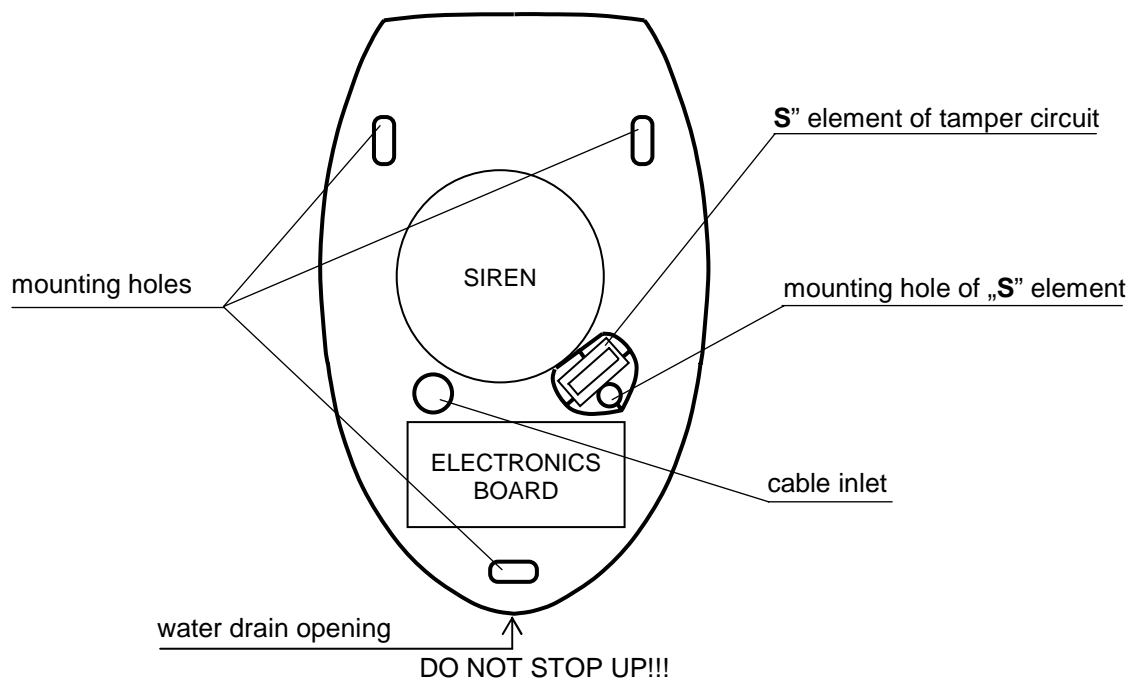

Fig. 1. View of siren housing (back part).

3. HOOKING UP

The SP-500 siren can work together with any source of alarm signal which, in the alarm condition, provides 12V direct voltage on the signaling output (outputs). The audible signaling of the SP-500 will be activated after connecting the 12V power supply to the "+ SA -" terminals, while the visual signaling will switch on when the 12V power is supplied to the "+ SO -" terminals. Both kinds of signaling can be controlled from one control panel output if the terminals are connected in parallel i.e. „+SA” with „+SO” and „-SA” with „-SO”.

The "TMP" terminals are designed for connecting the siren to the tamper circuit of the alarm system. The JP1–JP5 jumpers are intended for selection one of the siren acoustic signal.

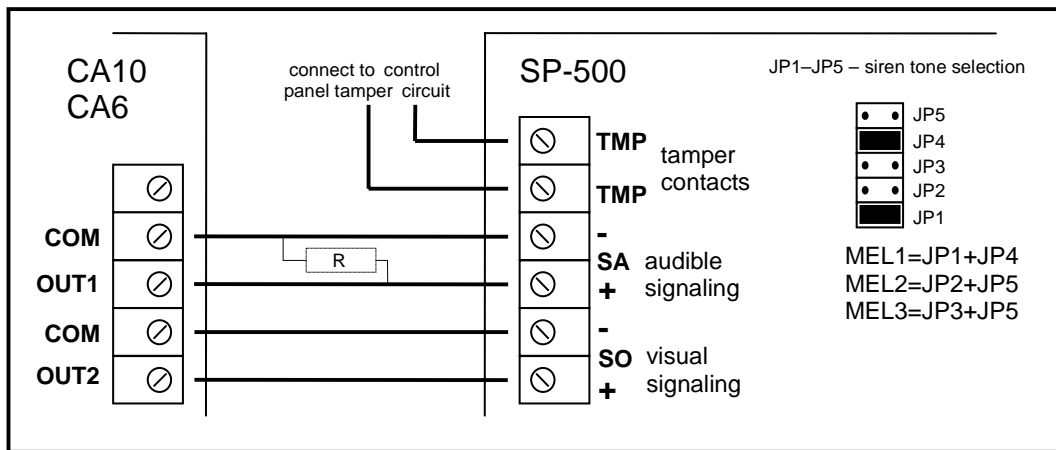

Fig. 2. Connection of the siren to the CA10 or CA6 alarm control panels.

The OUT1 and OUT2 outputs are programmed in the control panel as an alarm ones (BURGLARY or FIRE /BURGLARY), polarization +12V.

Some control panels may require a resistor R (about 1kΩ) to be installed in the siren. Otherwise, the siren will buzz silently when switched off.

4. TECHNICAL DATA

Supply voltage.....	12V DC ±15%
Current consumption – audible signaling.....	200 mA
Average/max. current consumption – visual signaling.....	350/500 mA
Average current consumption (SA and SO inputs connected in parallel).....	550 mA
Sound intensity.....	approx. 120 dB
Working temperature.....	-35°C...+55°C
Siren dimensions.....	300 x 195 x 97mm
Siren weight.....	731 g

SATEL sp. z o.o.
ul. Schuberta 79
80-172 Gdańsk
POLAND

tel. (+48 58) 320 94 00
www.satel.pl
info@satel.pl

Latest EC declaration of conformity
and product approval certificates can
be downloaded from our Web site
www.satel.pl

